



"Where sun shined
Power always on"



USER MANUAL

Lithium-ion Battery Pack Model:

U-P4850-7
U-P48100-7
U-P48150-7
U-P48200-7

Version: 1.0

CONTENT

1. Precaution.....	2
2. Parameters Of Battery.....	3
2-1.Parameters Of Battery Pack.....	3
2-2.Technical Parameters Of Battery Management System (BMS).....	4
3. Basic Block Diagram.....	8
4. Installation And Operation.....	9
4-1. Unpacking And Inspection.....	9
4-2. Panel View.....	9
4-3. Single Battery Installation.....	11
4-4. Software Installation.....	13
4-5. Installation Of Battery In Parallel.....	13
4-6 . Installation Precautions.....	13
4-7. Operation Instruction For Installation.....	14
4-8. Connection Mode For Parallel Communication.....	17
4-9. Monitor Soft.....	20
4-10. Upper Machine Instructions.....	20
4-11. Address Switch Function(only In Parallel).....	24
4-12. Communication Function.....	25
5. Operations.....	25
5-1. Led Indicators.....	25
5-2. Buzzer Operation(optional).....	27
5-3. Reset Key Function.....	27
6. Troubleshooting.....	28
7. Storage And Maintenance.....	28
7-1. Storage.....	28
7-2. Maintenance.....	29
8. Product Responsibilities And Consulting.....	30



Please comply with all warnings and operating instructions in this user manual strictly. Keep this manual properly and read carefully the following instructions before installing the unit. Do not operate this product before reading through all safety information and operating instructions carefully.

1.Safety Precaution

When Using the battery



Danger of High Voltage

The high voltage power supply offers the equipment power. Any wet object comes in contact with high voltage power supply directly or indirectly can cause fatal danger.



Using a special tool

When working with high voltage and AC power, make sure to use special tools instead of individual tools.



Prevent static electricity

Static electricity would damage the electrostatic sensitive devices. Before touching the plug, circuit board or chips, be sure to use the correct anti-static measures.



Disconnect the power supply in operation

Before operation, please make sure that the input power is cut off and the operation with power is prohibited.



Danger of DC short circuit

Power system provides DC regulated power supply. DC short circuit could cause fatal damage to the equipment.

When Charging the battery

⚠ CAUTION
The charging temperature of battery range from -5°C to 55°C. Charging beyond the temperature range may cause the battery to heat up and also damage the performance of the battery or result in a shortened life expectancy.

When Discharging the battery

⚠ DANGER
Do not discharge the battery using any device other than the specified device. When the battery is used in a device other than the specified one, it could damage the performance of the battery or shorten the battery lifespan, and if the device causes an abnormal flow of current, it may cause the battery to heat up and lead to serious damage.

⚠ CAUTION
The discharging temperature of battery range from -20°C to 65°C. Discharging beyond the temperature range may damage the performance of the battery or may result in a shortened life expectancy.

2 Parameters of Battery

2-1. Parameters of Battery Pack

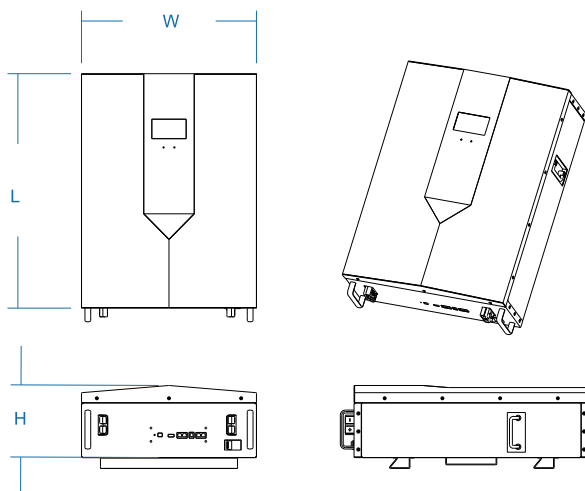

Figure 1

Model of battery pack	U-P4850-7	U-P48100-7	U-P48150-7	U-P48200-7
Nominal voltage	WLFP battery 48V			
Rated capacity	50Ah	100Ah	150Ah	200Ah
Rated reserved energy	2400Wh	4800Wh	7200Wh	9600Wh
Standard charging current	20A (BMS Limited)			
Recommend charging method	Charging with 20A constant current to 53V, then with constant voltage at 53V till charge current is $\leq 0.05C(CC/CV)$			
Total charge cut-off voltage	54.75V			
Charge cut-off voltage of cell	3.65V			
Standard discharging current	25A	50A	50A	50A
Maximum continuous discharging current	50A	100A	100A	100A
Discharge cut-off voltage of cell	2.5V			
Charging temperature range	0~55°C			
Discharging temperature range	-20~60°C			
Dimension (W×D×H)	450×370×200	650×485×200	650×485×220	650×485×250
Weight	40Kg	58Kg	77Kg	93Kg
Battery configuration	15S1P	15S1P	15S3P	15S2P
Storage temperature	0~45°C			

2-2. Technical Parameters of Battery Management System (BMS)

No.	Item	Parameter	Remark
1	Cell Over-charge	Cell Over-charge Voltage Alarm	3600mV
		Cell Over-charge Voltage Protection	3700mV
		Cell Over-charge Protection Delay Time	4.0S
	Cell Over-charge Protection Release	Cell Over-charge Release Voltage	3380mV
		Capacity Release	SOC<96%
		Discharge Release	Discharge Current > 1.0A

No.	Item		Parameter	Remark
2	Cell Over-discharge	Cell Over-discharge Voltage Alarm	2800mV	After 30s, the state changes to low-power mode
		Cell Over-discharge Voltage Protection	2500mV	
		Cell Over-discharge Voltage Protection Time	1.0S	
	Cell Over-discharge Protection Release	Cell Over-discharge Release Voltage	2900mV	
		Charge Release	Charger Connection is detected	
3	Pack Over-charge	Pack Over-charge Voltage Alarm	54.0V	PACK Voltage Precision \leq 300mV
		Pack Over-charge Voltage Protection	55.5V	
		Pack Over-charge Protection Delay Time	4.0S	
	Pack Over-charge Protection Release	Pack Over-charge Release Voltage	50.2V	
		Capacity Release	SOC<96%	
		Discharge Release	Discharge Current > 1.0A	
4	Pack Over-discharge	Pack Over-discharge Voltage Alarm	42V	After 30s, the state changes to low-power mode
		Pack Over-discharge Voltage Protection	37.5V	
		Pack Over-discharge Protection Delay Time	1.0S	
	Pack Over-discharge Protection Release	Pack Over-discharge Release Voltage	43.5V	
		Charge Release	Charger Connection is detected	

No.	Item		Parameter	Remark
5	Over-current Charge Protection	Over-current Charge Alarm	55A(U-P4850-7) 105A(U-P48100 /150/200-7)	When over-current charge protection appeared for 10 times continuously, the state will be locked and no longer be released automatically.
		Over-current Charge Protection	60A(U-P4850-7) 110A(U-P48100 /150/200-7)	
		Cell Over-discharge Protection Delay Time	1.0S	
		Charge Current Limit	20A(Charge current is \geq 100A to open the current Limit.) (50A/U-P4850-7)	
	Over-current Protection Release	Auto Release	After 1min	
		Discharge Release	Discharge Current > 1.0A	
6	Over-current Discharge Protection-1	Over-current Discharge Alarm	55A(U-P4850-7) 105A(U-P48100 /150/200-7)	Over-current discharge protection consecutive appeared 10 times, the state will be locked and will no longer be released automatically.
		Over-current Discharge Protection	60A(U-P4850-7) 110A(U-P48100 /150/200-7)	
		Over-current Protection Delay Time	1.0S	
	Over-current Protection Release	Auto Release	After 1min	
		Charge Release	Charge Current > 1.0A	
7	Over-current Discharge Protection-2	Over-current Discharge Protection-2	\geq 100A(U-P4850-7) \geq 150A(U-P48100 /150/200-7)	After 10 times, the state will be locked and will no longer be released automatically.
		Over-current Protection Delay Time	100mS	
	Over-current Protection Release	Auto Release	After 1min	
		Charge Release	Charge Current > 1.0A	
8	Short Circuit Current Protection	Short Circuit Threshold Protection	Yes	
		Short Circuit Current Protection Release	Charge Current > 1.0A	
	Remove the Load			

No.	Item	Parameter	Remark
9	MOS Over-Temperature Protection	MOS Over Temperature Alarm	90°C
		MOS Over Temperature Protection	115°C
		MOS Over Temperature Protection Release	85°C
10	Cell Temperature Protection	Low Temperature Charge Alarm	5°C
		Low Temperature Charge Protection	0°C
		Low Temperature Charge Protection Release	5°C
		Over Temperature Charge Alarm	55°C
		Over Temperature Charge Protection	60°C
		Over Temperature Charge Protection Release	50°C
		Low Temperature Discharge Alarm	-15°C
		Low Temperature Discharge Protection	-20°C
		Low Temperature Discharge Protection Release	-15°C
		Over Temperature Discharge Alarm	60°C
		Over Temperature Discharge Protection	65°C
		Over Temperature Discharge Protection Release	55°C
11	ENV Temperature Alarm	ENV Low Temperature Alarm	-15°C
		ENV Low Temperature Protection	-25°C
		ENV Low Temperature Protection Release	-15°C
		ENV Over Temperature Alarm	65°C
		ENV Over Temperature Protection	75°C
		ENV Over Temperature Protection Release	65°C

No.	Item	Parameter	Remark
12	Consumption	Operation Mode	40mA(with LCD)
		Low Power Mode	100µA
13	Cell Balance	Balance Threshold	3500mV(default)
		ΔVcell	30mV(default)
14	Capacity	Low Capacity Alarm	SOC<5% No alarm when charging
15	Sleep Mode	Sleep Voltage	3150mV
		Delay time	5min

3. Basic Block Diagram

There are Battery cells and BMS board inside, before connecting the terminal, please read the diagram, and make sure there is no short circuit or other abnormal connection for the output.

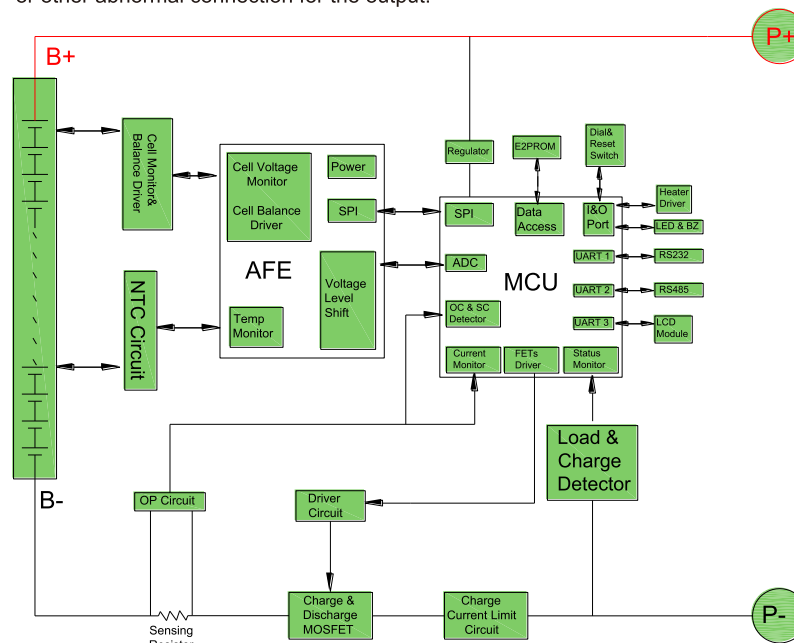

Figure 2 Battery Block Diagram

4. Installation and Operation

4-1. Unpacking and Inspection

Unpack the package and check the package contents. The shipping package contains:

- One Battery
- Two mounting brackets
- A small bag of screws and nuts

NOTE: Before installation, please inspect the unit. Be sure that nothing inside the package is damaged during transportation. Do not turn on the unit and please notify the carrier and dealer immediately if there is any damage or lacking of components. Please keep the original package in a safe place for future use.

4-2. Panel View

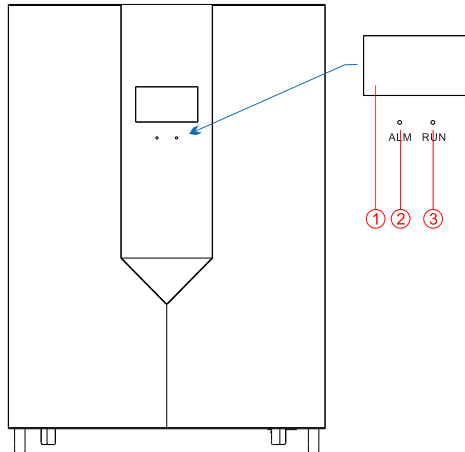

Figure 3 Product front view

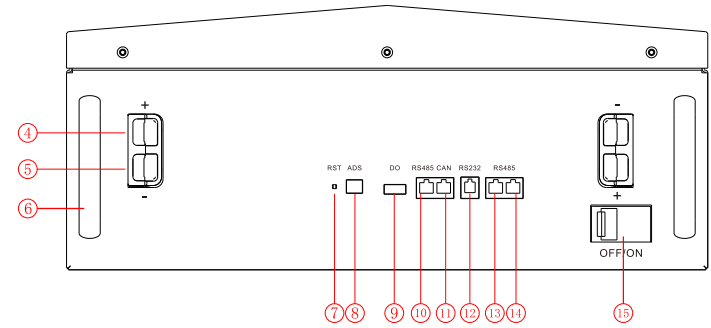

Figure 4 Product panel diagram

No.	Description	Functional Description
1	LCD	Display battery status information
2	Red- trouble-light on	ALM alarm indicator light blinking
3	Display state information	Run indicator light blinking
4	Battery +	Positive terminal
5	Battery -	Negative terminal
6	Handle	Handling
7	Reset key	On/OFF button
8	Display connection address	ADS Dialer
9	Dry contact	1/2 Normally open, closed during fault protection 3/4 Normally open, closed when a low battery alarm signal has occurred
10	RS-485 connection port	RS 485 communication interface
11	CAN connection port	CAN communication interface
12	RS-232 connection port	RS 232 communication interface (for battery condition monitoring)
13	RS-485 connection port	RS 485 communication interface (Used in communication parallel, and for battery condition monitoring or manufacturer to debug or service)
14	RS-485 connection port	RS 485 communication interface (Used in communication parallel, and for battery condition monitoring or manufacturer to debug or service)
15	MCB	Output ON/OFF

4-3. Single battery Installation

(1).Drill 4-12 holes suitable for M8X60 explosive screws on the mounting wall surface as shown in figure 5 , and install the explosive screw.

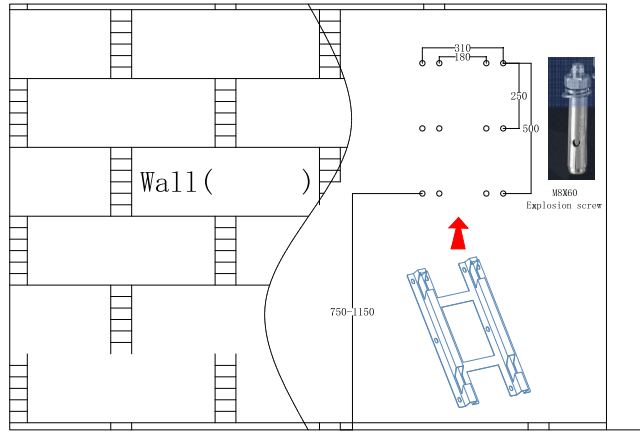

Figure 5

(2).Insert the mounting hole of the bracket into the explosion screw (close to the wall) and lock it with M8 nut.

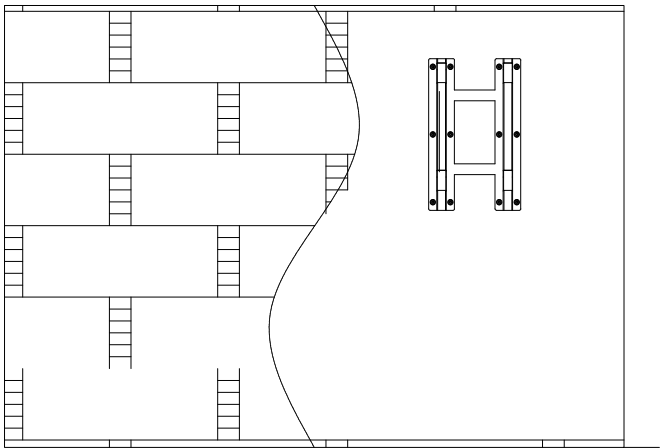

Figure 6

(3).Take the battery and move it in the direction shown in figure 7 below.

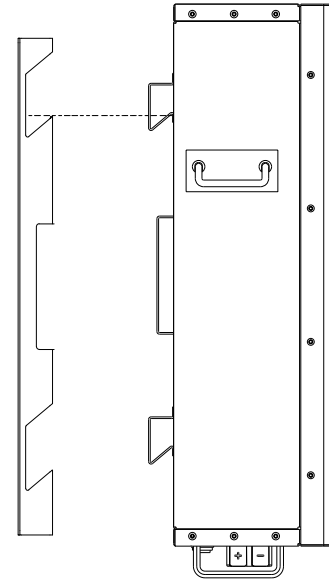

Figure 7

(4).Move in the direction as shown in figure 8, and fit well, as shown in figure 9.

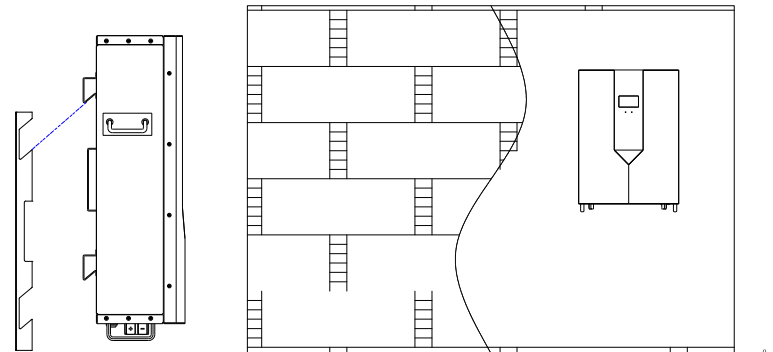

Figure 8

Figure 9

4-4. Software Installation

For optional computer system protection, installing battery monitoring software to fully configure battery shutdown and other setting value.

4-5. Installation of Battery in Parallel

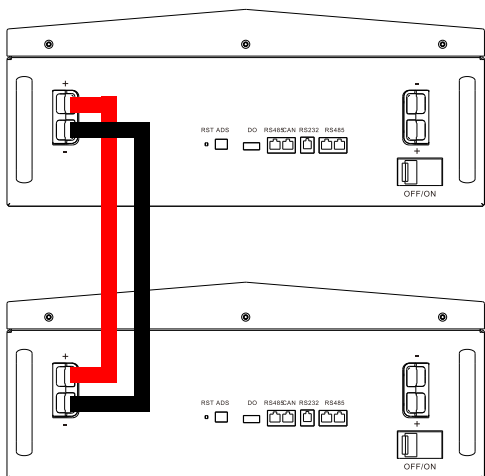

Figure 10

4-6. Installation Precautions

- (1) Before installation, unpacking to check the quantity of the components and battery appearance.
- (2) Different brands of batteries or new and old batteries cannot be used in parallel.
- (3) Static voltage differences $\leq 0.2V$, SOC differences $\leq 5\%$, internal resistance differences $\leq 2m\Omega$ can be used together in parallel.
- (4) Install the hanger and handle and then measure the battery voltage with a multimeter. The general factory voltage of the battery is 48V-50.25V.
- (5) Before wiring, check the anode and cathode of the battery. Make sure that the anode and cathode terminals shall not be connected reversely.
- (6) During battery connection, please wear the protective gloves. When using some metal objects such as torque wrench, please package them with insulation materials. Both end of the torque wrench or other metal tools shall not contact the positive and negative terminals of the battery at the same time in order to avoid battery short-circuit.

(7) Before the battery is connected with the externally connected equipment, making sure the equipment is in a disconnected state. Check again whether the connecting polarity of the battery and total voltage are correct, then connect the battery anode with the equipment anode and connect the battery cathode with the equipment cathode. Finally fix the connecting line.

(8) During handling and placement, the battery must be handled gently. Avoid dropping or impacting. The battery shall not be thrown or stricken to avoid damaging the battery or resulting in potential safety hazard.

(9) Do not touch the surface of the battery box with the sharp part of the tool which could scratch or damage the battery box.

(10) Do not disassemble the battery box without authorization.

(11) Do not store the battery together with other metal objects made of conducting material or assemble it into the battery box.

(12) Install it according to the selected installation mode:

Installation of standard cabinet (rack): Install the matching hanger for the battery pack and fix them in the standard cabinet and the tray protection is added for the battery box.

Installation of wall-mounted box: Prior to installation, please ensure that the wall complies with the wall-mounted requirements. According to the location in the design plan, installing the special wall-mounted box of the lithium battery; the battery pack is fixed in the wall-mounted box in a hanger manner.

Installation of integrated indoor and outdoor cabinets (boxes): Install them according to the installation specification of the customized integrated cabinet (box).

4-7. Operation Instruction for Installation

(1) Prior to installation, please check whether the battery is normal.

Press the reset key RST on the front panel for 3s for start-up. During the start-up period, 4 capacity indicator lights on the front panel, ALM alarm indicator light (red) and RUN indicator will light up. Please check whether all indicator lights light up normally. Then the ALM alarm indicator light turns off, the RUN indicator light and the capacity indicator light light up according to the capacity.

If the ALM alarm indicator light is flashing after start-up, it means that the battery has an alarm. The newly installed battery seldom has an alarm. The common alarm is the battery undervoltage alarm (which is resulted from not using the battery for a long time). Such situation may be solved after the battery is charged for 30mins. If the alarm may not stop, please press the reset key RST

for 10s, until all the LEDs light up for reset, perform the battery reset operation and confirm whether the alarm could be turned off. If the alarm is off, the battery may be used normally. Otherwise the battery shall be reworked.

(2) For the battery which is normal after detection, please press the reset key RST for 3s to execute the battery ON/OFF operation.

Instructions of manual operation of the reset key RST	Start-up	In the OFF state of BMS, press the key for 3s for Start-up;
	Shut down	In the non-standby state of BMS, press the key for 3s for shutdown;
	Reset	In the non-standby state of BMS, press the key for 10s until all the LEDs light up for reset.

Instructions: "Shutdown" and "standby" have the same meaning in Chinese, "start-up" and "activation" also have the same meaning in Chinese.

(3) Installation of the lithium battery, wiring and start-up.

Make the battery packs in a standby state, install them in the battery cabinet one by one, the anode and cathode of the battery pack are connected respectively to the switching power supply or UPS (Please note that the switching power supply and UPS shall be disconnected from the AC). Press the reset key RST of one of battery packs for 3s for start-up (Such kind of start-up may activate other batteries which are connected in parallel) or press the reset key RST of each battery pack for 3s successively, and the whole battery pack with high capacity enters the working state. Later, apply AC to the power supply equipment such as switching power supply and UPS to make the whole standby system run.

The specification of the connecting line is selected according to the load current.

Note: We do not equip with the battery connecting line by default, which shall be selected according to the total capacity of the battery pack.

Lithium battery	Copper core cable	Copper pigtail	Remarks
48V50Ah	16mm ²	25-8	M8 copper pigtail is used for 48V battery binding post
48V100Ah/ 150Ah/200Ah	35mm ²	35-8	M8 copper pigtail is used for 48V battery binding post

Battery pack in parallel (the wiring diagram is shown in Figure 11 or Figure 12):

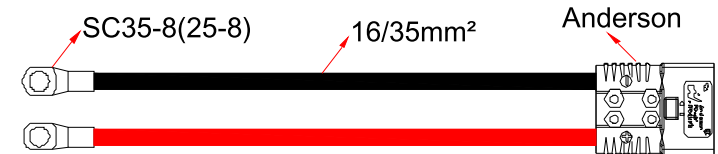

Figure 11



Figure 12

Step 1: Make the battery pack in the standby state and install it in the cabinet successively.

Step 2: Disassemble the anode insulating cap of the adjacent batteries one by one, connect the anodes of the adjacent battery packs with the installation connecting line and screw on the anode insulating cap.

Step 3: According to step 2, connect the cathode of the battery pack.

Step 4: Set the dial-up addresses of all battery modules from top to bottom one by one, which respectively are 1000, 0100, 1100 and 0010 (the dial-up addresses are set according to the number of battery modules actually used). (This step may be skipped if there is no need to access to the remote monitoring platform.)

Step 5: Perform the cascade connection to RS485 communication interface of the battery module with the RS485 connecting line; lead the RS232 interface of the battery module with the address of 1000 to the collector of the monitoring platform with the RS232 connecting line. (This step may be skipped if there is no need to access to the remote monitoring platform.)

Step 6: Draw out two wires from the anode and cathode of a battery pack at the top or in the middle respectively, which are used as the main connecting line of the battery pack in parallel and are connected with the switching power supply or UPS.

Step 7: Press the RST key of each battery pack for Reset and the whole battery pack with high capacity enters the working state.

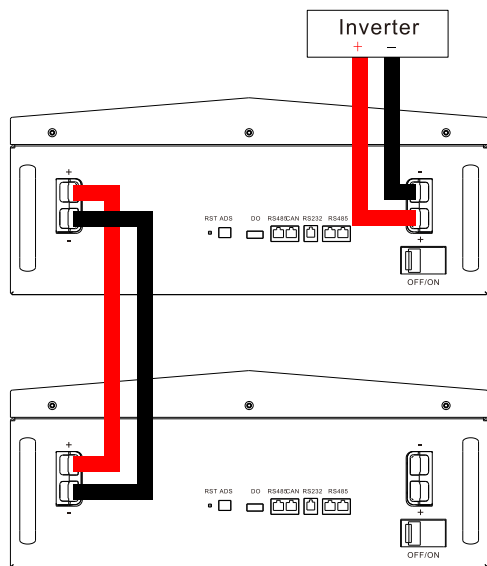

Wiring Diagram of Battery Pack in Parallel (Figure 13)

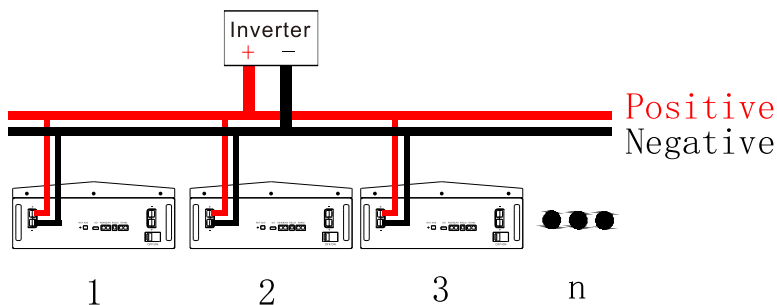

Wiring Diagram of Battery Pack in Parallel (Figure 14)

Circuit breaker of battery circuit is set as OFF, connect it to switching power supply. The output voltage of switching power supply is set as 52.5-54V, and the current is set as 0.2C. After all the settings have been done, switch the circuit breaker ON.

4-8. Connection mode for parallel communication

Single battery communication

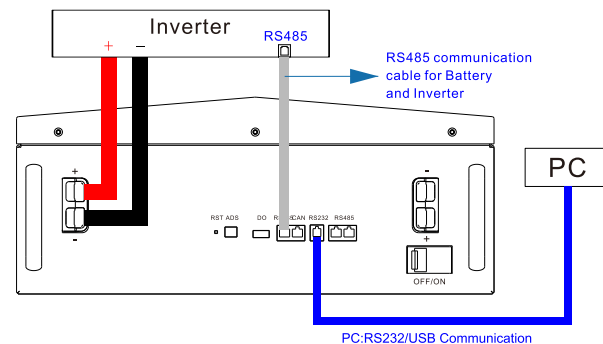

Figure 15

PC:RS232/USB Communication
Inverter: RS485 Communication

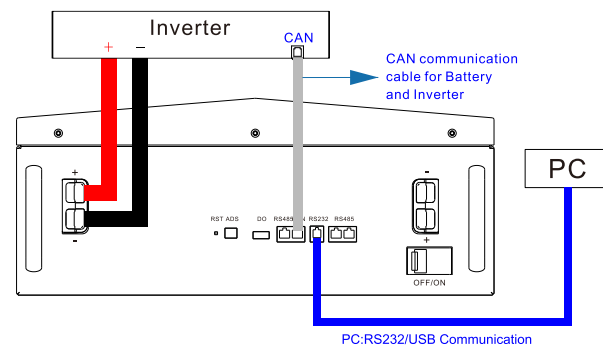

Figure 16

PC:RS232/USB Communication
Inverter: CAN Communication

While in parallel communication, the dial-up addresses of battery module are 1,2,3,4.....14,15, where 1 stands for the host computer, the data of other batteries are uploaded to the host and the host computer conducts unified uploading. The host computer with dial-up code of 1 is required to connect with upper computer; FF polling mode used as consulting mode.

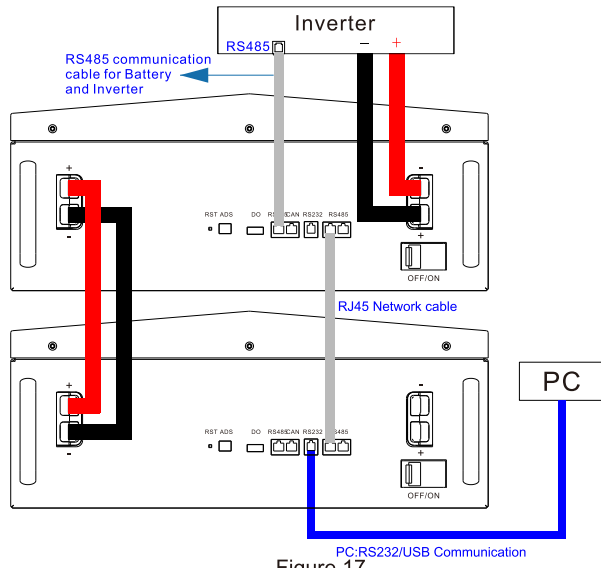

Figure 17

PC:RS232/USB Communication
 Inverter: RS485 Communication

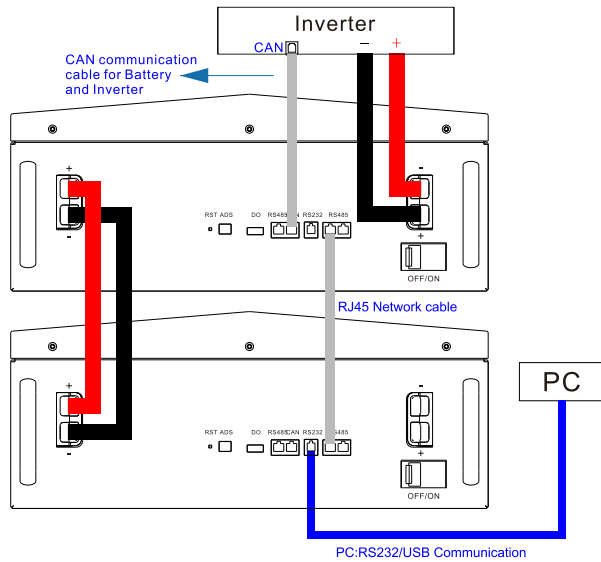

Figure 18

PC:RS232/USB Communication
 Inverter: CAN Communication

4-9. Monitor Software interface

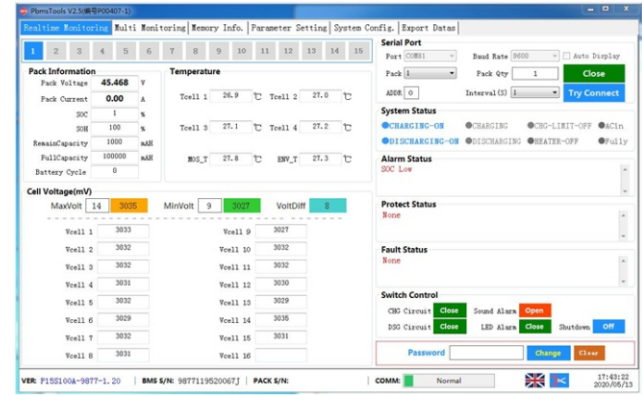

Figure 19

4-10 Upper machine instructions

A. Software source file

Name of software source file: Unzip the "Pbms Tools V2.5.zip" file and get "config", "Pbms Tools .exe", "Pbms Tools.exe.config" three documents in total.

B. Software running environment

The software runs on the PC and its compatible computer, using WINDOWS operation system.

C. Software using steps

(1) Double click Pbms Tools .exe icon can show the main interface of the software (As shown in figure 20).

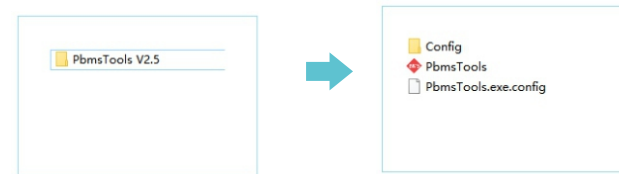

RS 232 PC software

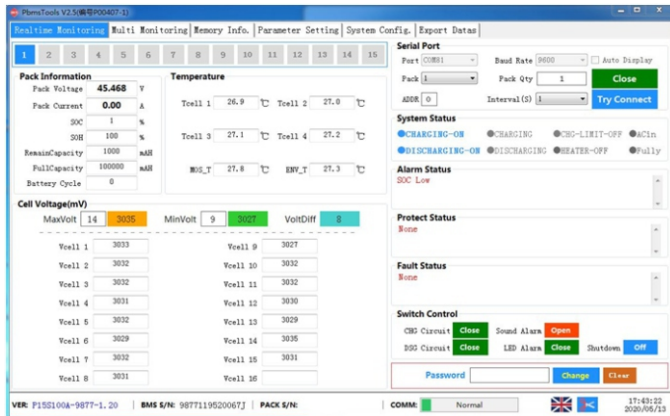

Figure 20: Realtime Monitoring

(2) Open the main interface (As shown in figure 20), the software will search serial port and open automatically, and read the battery voltage, temperature, protection state and other battery parameters in real time. Operating authority is divided into general permissions and administrator permissions.

(3) In the Data Storage (As shown in figure 21 and 22),

Figure 21 there are two check boxes: display and Record Data.

Check the display option, can display the various parameters of the battery in real time.

Check the Record Data option and click "Export" to automatically export the battery parameters in the excel sheet.

Date/Time	Pack No	BMS S/N	Pack S/N	Pack Current(A)	Pack Voltage(V)	RemainCapacity(%)	FullCapacity(Ah)
2020-05-13 17:45:02	1	9877119520067J	28962005...	0.00	45.466	1.000	100.000
2020-05-13 17:45:03	1	9877119520067J	28962005...	0.00	45.466	1.000	100.000
2020-05-13 17:45:04	1	9877119520067J	28962005...	0.00	45.466	1.000	100.000
2020-05-13 17:45:05	1	9877119520067J	28962005...	0.00	45.465	1.000	100.000
2020-05-13 17:45:06	1	9877119520067J	28962005...	0.00	45.465	1.000	100.000
2020-05-13 17:45:07	1	9877119520067J	28962005...	0.00	45.465	1.000	100.000
2020-05-13 17:45:08	1	9877119520067J	28962005...	0.00	45.465	1.000	100.000
2020-05-13 17:45:09	1	9877119520067J	28962005...	0.00	45.465	1.000	100.000
2020-05-13 17:45:10	1	9877119520067J	28962005...	0.00	45.465	1.000	100.000
2020-05-13 17:45:11	1	9877119520067J	28962005...	0.00	45.465	1.000	100.000
2020-05-13 17:45:12	1	9877119520067J	28962005...	0.00	45.465	1.000	100.000
2020-05-13 17:45:13	1	9877119520067J	28962005...	0.00	45.465	1.000	100.000
2020-05-13 17:45:14	1	9877119520067J	28962005...	0.00	45.466	1.000	100.000
2020-05-13 17:45:15	1	9877119520067J	28962005...	0.00	45.466	1.000	100.000
2020-05-13 17:45:16	1	9877119520067J	28962005...	0.00	45.466	1.000	100.000
2020-05-13 17:45:17	1	9877119520067J	28962005...	0.00	45.466	1.000	100.000
2020-05-13 17:45:18	1	9877119520067J	28962005...	0.00	45.466	1.000	100.000
2020-05-13 17:45:19	1	9877119520067J	28962005...	0.00	45.466	1.000	100.000
2020-05-13 17:45:20	1	9877119520067J	28962005...	0.00	45.466	1.000	100.000
2020-05-13 17:45:21	1	9877119520067J	28962005...	0.00	45.466	1.000	100.000

Figure 21: Multi Monitoring

Figure 22 there are two check boxes: Export and Delete.

The files in all tables are located under the current file path of the data folder and are the backup files of Multi Monitoring in Figure 21. The storage file name is named according to the data recording time, such as 2020_04_30-091402.

"Export" can export the currently selected data and "Delete" can delete the currently selected data.

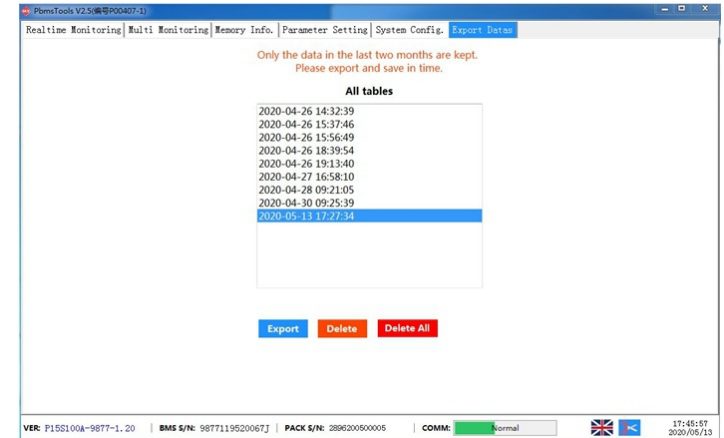

Figure 22: Export Data

(4) In the Memory Information (As shown figure 23), this page is for reading battery history, including any BMS alarms and battery status information during the protection.

Read BMS time: Read BMS original write time;

Write To BMS: BMS calibration to PC time;

Memory Setting: Read history, delete history, pause reading history, save history

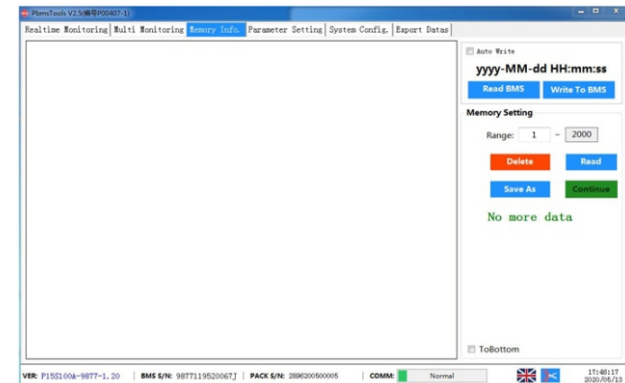

Figure 23:Memory Information

(5) In the Parameter Settings (As shown figure 24), this page shows the BMS parameters.

Read all: Read all the parameters of the BMS

Write in parameter: Write all the parameters of the BMS

Restore default: Restore the default parameters for battery

Reset setting: Revert to the original default value of BMS

Import: Export the current battery parameters, for the XML file format.

Export: The parameters of the import file format for the XML to the current TAB

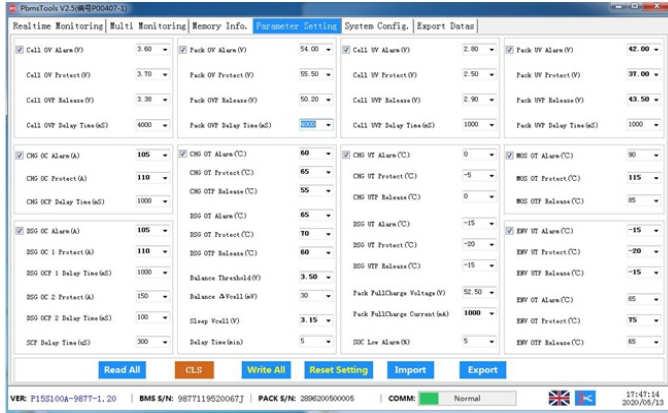

Figure 24: Parameter Settings

(6) In the system configuration TAB (As shown in figure 25), the TAB for battery calibration, parameters setting, the battery calibration and setting up the battery system parameters need administrator privileges.

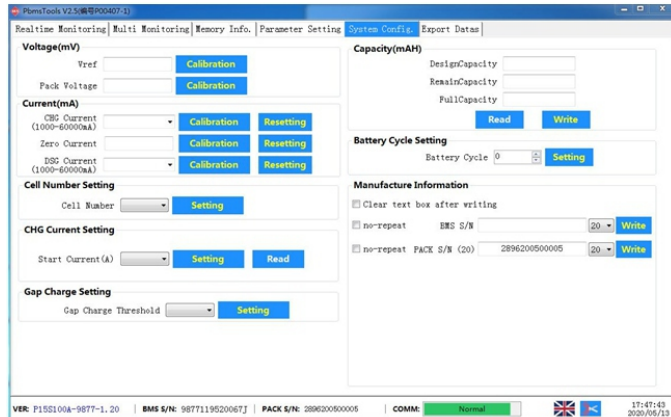

Figure 25: System Configuration

(7) In the Upper Setting (As shown in figure 26), software language can be set.

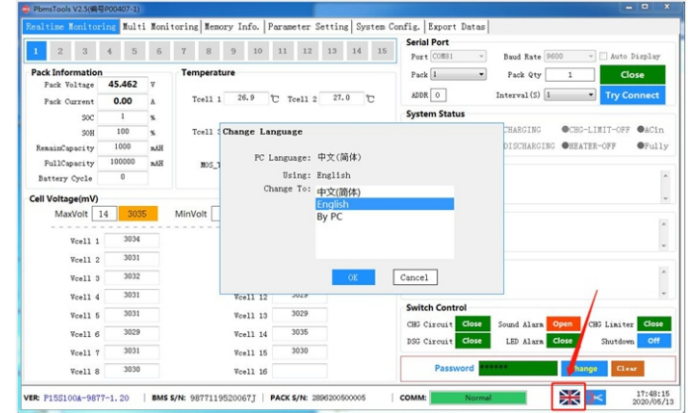
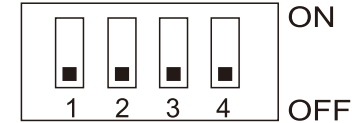

Figure 26: Upper Setting

4-11 Address Switch function (Only in Parallel)

When battery work in parallel, main pack and slave packs need address as follows:



Address	Dial Switch				Remark
	#1	#2	#3	#4	
0	OFF	OFF	OFF	OFF	
1	ON	OFF	OFF	OFF	Pack1(Main Pack)
2	OFF	ON	OFF	OFF	Pack2
3	ON	ON	OFF	OFF	Pack3
4	OFF	OFF	ON	OFF	Pack4
5	ON	OFF	ON	OFF	Pack5
6	OFF	ON	ON	OFF	Pack6
7	ON	ON	ON	OFF	Pack7
8	OFF	OFF	OFF	ON	Pack8
9	ON	OFF	OFF	ON	Pack9
10	OFF	ON	OFF	ON	Pack10
11	ON	ON	OFF	ON	Pack11
12	OFF	OFF	ON	ON	Pack12
13	ON	OFF	ON	ON	Pack13
14	OFF	ON	ON	ON	Pack14
15	ON	ON	ON	ON	Pack15

4-12 Communication Function

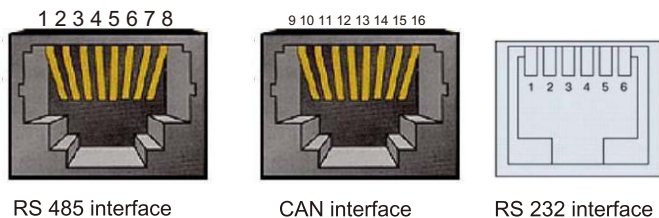

Figure 27 Communication Port Interface

Rs485 Terminal Port	Definition	CAN Terminal Port	Definition
Pin1,8	RS485_B	Pin9,10,11,14,16	NC
Pin2,7	RS485_A	Pin12	CANL
Pin3,6	GND	Pin13	CANH
Pin4,5	NC	Pin15	GND

RS485&CAN Communication Port Definition

Rs232 Terminal Port	Definition
Pin3	BMS Transmit, PC Receive
Pin4	BMS Receive, PC Transmit
Pin5	GND
Pin1,2,6	NC

RS232Communication Port Definition

5. Operations

5-1. LED Indicators

LED Indicators:

There are 2 LEDs on front panel to show the battery working status:

PACK Status	Normal/ Alarm/ Protection	RUN	ALM	Remark
		●	●	
Power Off	Sleep	OFF	OFF	All off
Standby	Normal	Flash 1	OFF	Standby state
	Alarm	Flash 1	Flash 3	Cell low voltage
Charge	Normal	ON	OFF	ALM Led is OFF when Cell over-charge or Pack over-charge Alarm
	Alarm	ON	Flash 3	
	Over Charge Protection	ON	OFF	If no mains supply, LED as standby
	Temperature Over-current Fault Protection	OFF	ON	Close charge
Discharge	Normal	Flash 3	OFF	
	Alarm	Flash 3	Flash 3	
	Under Discharge Protection	OFF	OFF	Close discharge
	Temperature Over-current Short Circuit Fault Protection	OFF	ON	Close discharge
Fault		OFF	ON	Close charge Close discharge

Figure 28 LED Operating Status

Flash	ON	OFF
Flash1	0.25Sec	3.75Sec
Flash2	0.5Sec	0.5Sec
Flash3	0.5Sec	1.5Sec

NOTE: LED function can be set by monitor software, it is enabled by default.

5-2. Buzzer Operation (Optional)

Model	Description and Status
Fault	Buzzing 0.25S per 1Sec
Protection	Buzzing 0.25S per 2Sec (expect for over-charge protection)
Alarm	Buzzing 0.25S per 3Sec (expect for over-charge alarm)

NOTE: Buzzer function can be set by monitor software, it is closed by default.

5-3. Reset key function

Mode	Pressing and Holding time		
	0-3Sec	3-6Sec	>6Sec
Normal	Indication by SOC	Transfer to Sleeping mode	Reset
Sleeping Mode	Wake up from Sleeping mode		

5.3.1 Battery parameters collection page.

When the cursor“》”is point to “Battery Parameters Acquisition” , press ENTER key will enter into the page of“Battery Parameters Acquisition”.

5.3.2 Key description.

- 1)SW1----MENU , SW2----ENTER , SW3----DOWN , SW4----ESC.
- 2)Each item is “》” or“--”as a beginning , among them“》” shows the current cursor position , press DOWN key can move the cursor position ; with“》”end of the project , the content of the said project has not shown, press ENTER key can enter the corresponding page.
- 3)Press ESC key can be returned at the next higher level directory ; In any position , press MENU key can return to the main menu page.
- 4)In a dormant state, press any key, can activate the screen.

5.3.3 Dormancy/shutdown.

Under normal operation condition, with no keystrokes 1 minutes later, system will enter a state of dormancy/shutdown.Shutdown/dormancy state , press any key , screen can be activated.

6. Troubleshooting

If the battery does not operate correctly, please using the table below to solve the problem.

Symptom	Possible cause	Remedy
No indication and alarm in the front display panel	Sleeping mode	Press Reset to normal mode
No indication and alarm in the front display panel even after the Reset	Battery voltage is too low	Charge battery immediately
Red LED Flashing when Standby	Battery cell low voltage	Charge battery immediately
Red LED Flashing when charging	Alarm for protection when charging	BMS displays alarm, protection and adjustment
Red LED Flashing when Discharging	Battery capacity is too low and will shutdown	Charge battery immediately
RED LED light is on continuously	Battery wrong	Need to repair

7. Storage and Maintenance

7-1. Storage

Storage Temperature Recharge Frequency Charging Duration

0°C - 45°C Every 3 months 1-2 hours

Before storing, charge the battery at least 7 hours. Cover the battery covered and store it upright in a cool and dry place. Long-term storage temperature of 15°C -25°C is recommend. During storage period, recharge the battery in accordance with the following table:

Storage Temperature	Recharge Frequency	Charging Duration
0°C - 45°C	Every 3 months	1-2 hours

7-2. Maintenance



The battery system operates with hazardous voltages. Repairs must be carried out only by qualified maintenance personnel.



Even after the unit is disconnected from the power supply, the internal components are still connected to the battery cells, which is potentially dangerous.



Before carrying out any kind of service and/or maintenance, disconnect the batteries and make sure that no current and hazardous voltage exists in the terminals.



Only those who are fully familiar with batteries and have the required precaution may replace the batteries and supervise operations. Unauthorized personnel are strictly prohibited to disassemble the battery.



Verify that there is no voltage between the battery terminals and the ground before maintenance or repair. In this product, the battery circuit is not isolated from the input voltage. Hazardous voltages may occur between the battery terminals and the ground.



Batteries may cause electric shock and have a high short-circuit current. Please remove all wristwatches, rings and other metal personal objects before maintenance or repair, and only use tools with insulated grips and handles for maintaining or repairing.



When replace the batteries, install the same number and same type of batteries.



When replace the parallel batteries, make sure the new battery is full charged.



Do not open or destroy batteries. Escaping electrolyte can cause injury to the skin and eyes. It could be toxic.



Please replace the fuse only with the same type and amperage in order to avoid fire hazards.



Do not disassemble the battery system.

8. Product Responsibilities and Consulting

- (1) We will not be liable for the accidents resulting from operation that violates this specification and user manual.
- (2) We will not inform separately provided that the contents of this specification are subject to change due to product quality improvement or technical improvement. If you want to understand the latest information of this product, please contact us.
- (3) We will maintain the product which is in the warranty period for free of charge. If there is a product quality problem within the specified operation range and fail to be repaired, we may replace the relevant parts so as to achieve the purpose of sustainable use without reducing the performance. Our after-sales service personnel will propose the specific maintenance and troubleshooting methods.